



Although the installer's intention was to create a "primary loop," that's not what he ended up with. The two high-temperature zones are piped across the loop rather than into pairs of closely spaced tees. The "primary circulator" will also induce hot water migration into the higher temperature zones due to the head loss around the remainder of the "primary loop."

Another problem is the lack of a thermal trap, or check valve to stop heat migration through the injection risers when the injection pump is off, but the "primary circulator" is operating. Although the drop leg in the piping might constitute a "trap" of sorts, it will not stop heat migration into the injection risers.

There is no need to create a primary loop in this system. Provided the headers are relatively short and generously sized (flow velocity less than 4 feet per second with all circulators running), the injection pump can be piped across the headers as shown in the fix drawing. However, be sure that a check valve is used in the injection circulator.

There should also be purging valves on the return side of all zone circuits, and these valve need to be installed in the correct orientation. The glitch drawing shows them upside down on the return side of the high temperature zones.

There is no air separator in the glitch drawing. The fix drawing shows the air separator installed, so flow leaving the boiler passes through it in both space heating and domestic water heating modes.

The boiler's supply temperature sensor is mounted too close the closely spaced tees. In this position, the mixing between the incoming boiler water and system bypass water is not complete, and the temperature has not settled to the final blended value supplied to the distribution system. Ditto for the supply sensor of the injection mixing controller. The controls will respond to incorrect temperatures.

There is no need for the injection mixing controller to sense boiler return temperature with a condensing capable boiler.

Finally, a ball valve is not a good choice for balancing the return injection riser. A globe valve or other valve specifically intended for balancing should be used.

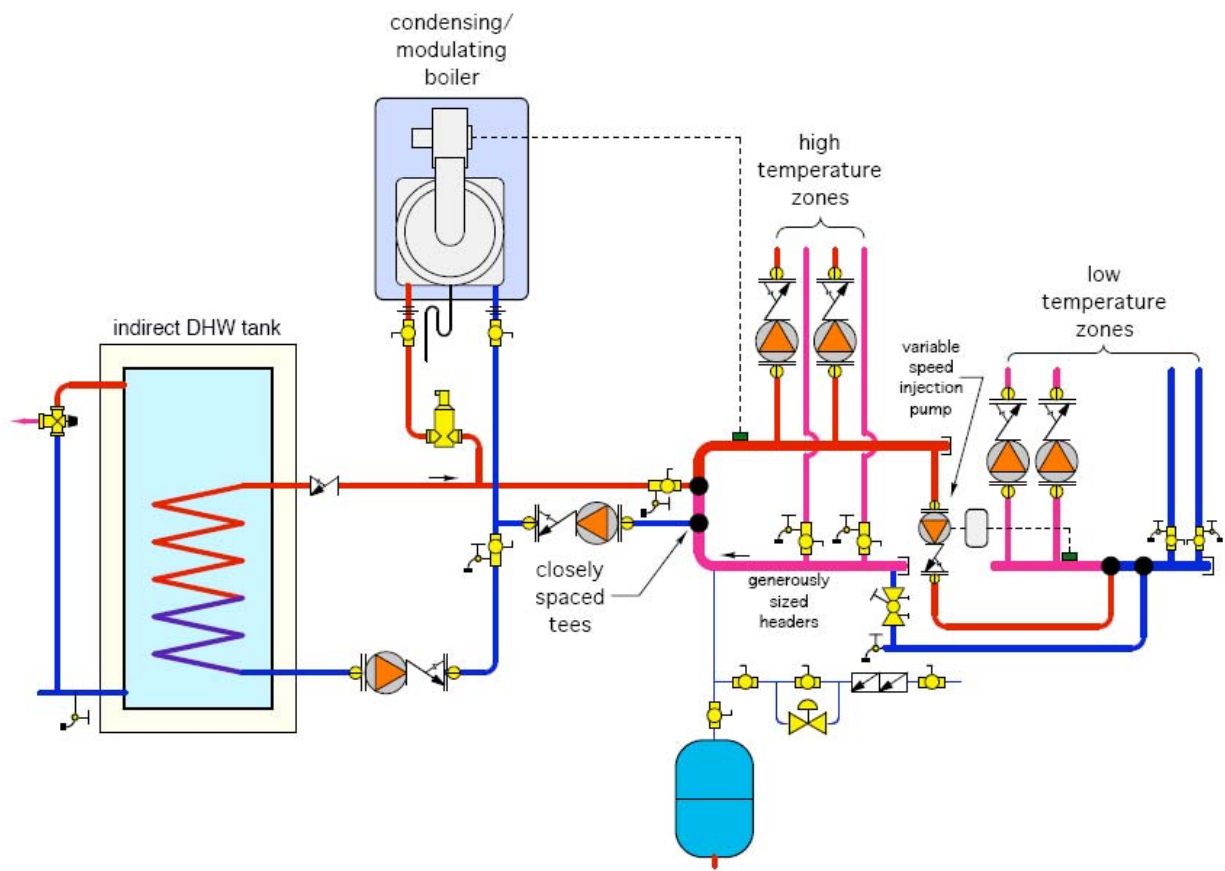

Visit [www.HydronicPros.com](http://www.HydronicPros.com)